

## HBS HOLLOW BAR SYSTEM

The great innovation of this unique system lies in the methods and means to add lines of compressed air and other fluids under pressure. The system is mainly composed of an extruded aluminium bar, which presents an external rectangular section with tee slots and an internal bore of large dimension to carry a considerable flow of compressed air.

A wide selection of straight joints, T or I joints allows for airlines of whatever length and shape. To complete the equipment we supply a number of outlet plates of various dimensions and shapes. The Teseo Modular aluminium Pipework System is leak free due to positive o-ring seals.

### The following advantages stand out:

- Fast installation.
- Quick installation of additional outlets.
- Easy to make changes and add new branch lines.
- Clean and smooth inner and outer surfaces.
- Integrated modular system

### EASY TO ASSEMBLE

#### DEBURRING



#### MOUNTING



#### ASSEMBLING

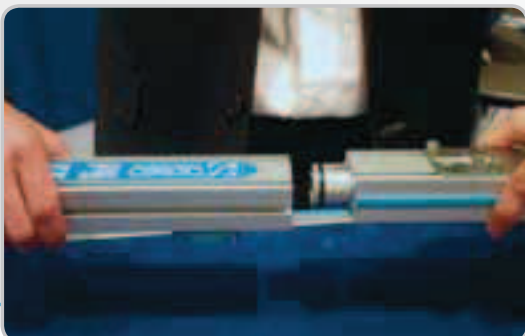

#### TIGHTENING



## BLUE DESIGN

The new generation of the blue in **TESEO** is the result of the modification and the improvement of all the TESEO systems.

Our continuous R & D into **Energy Saving** together with a high regard for the **Design** ruled our technical choices. We studied the internal passages and the thicknesses to increase the flow rates through our tubing.

**Double seats for the O-rings** and high quality NBR **Blue O-Rings**, manufactured for Teseo, are applied to all the connections for high quality sealing.

**Ergonomics** of the complete system has been improved thanks to optimization of the shapes and weights. Precision manufacturing carried out on many components improves the outer finishing and removes the die-casting defects.

**Outlet plates** have been re-designed with new moulds, to improve quality and accuracy.

The blocking parts have been analyzed and improved.

**The implementation** of accessories and components is continuous.

Teseo are sourcing **New certifications** and international compatibility.



Indicative diagram for the choice of the HBS diameter according to compressor installed max power.

Compressor power kW	HBS diameter D	Indicative flow rate (L 30 m - 6 bar - $\Delta p$ 3%) NI/min
19	25	2.900
36	32	5.400
110	50	16.400
195	63	29.200
350	80	53.000
785	110	117.500



Indicative diagrams of compressed air flow rates and related pressure drops in a line 30 m long (20°C - 1013 mbar).

The data used has been provided by the UNIVERSITY OF TURIN. See online software (page 9)

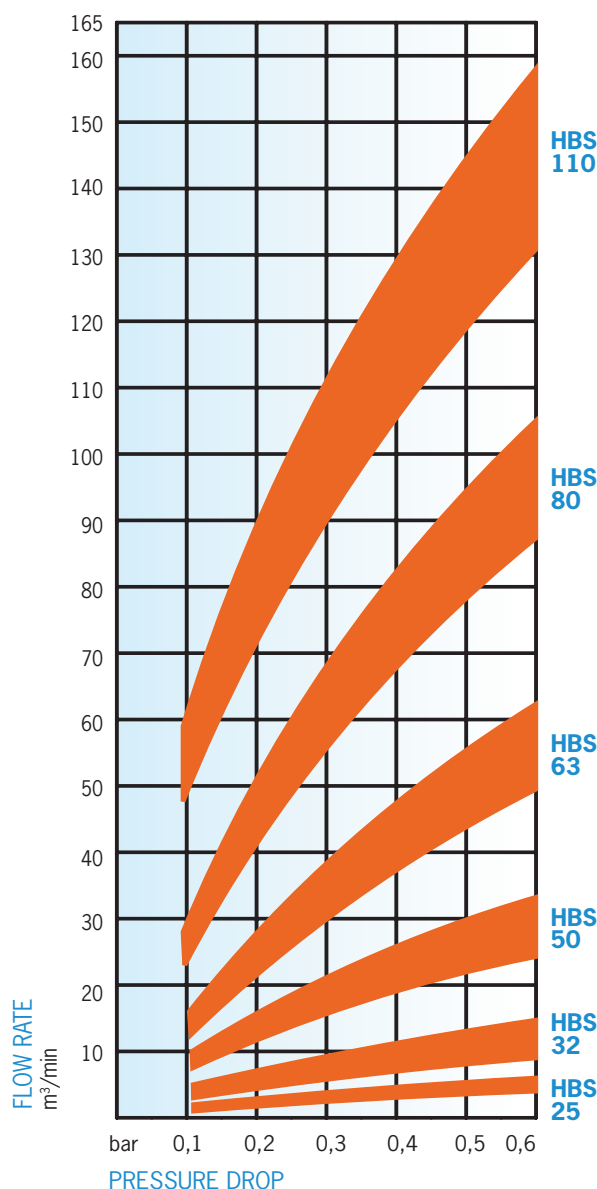

AIR PRESSURE: 6→12 bar 0,6→1,2 MPa 87→174 psi

## TECHNICAL CHARACTERISTICS

Extruded Aluminium .....	<b>Alloy EN AW-6060 UNI EN 573-3:1996</b>
International designations .....	<b>ANSI 6060 - DIN1748/1: AlMgSi 0,5 BS 6060</b>
Chemical composition .....	<b>Si: 0,45 - Mg: 0,45 - Fe: 0,3</b>
Heat treatment .....	<b>Aging T5 o T6</b>
Surface treatment (upon request) .....	<b>Chemical silver anodization</b>
Specific weight, density .....	<b>Kg/dm<sup>3</sup> 2,71</b>
Electrical conductivity .....	<b>% IACS 53</b>
Thermal Conductivity .....	<b>W/m-K 200</b>
Specific heat.....	<b>J/Kg-K 96</b>
Coefficient of expansion.....	<b>mm/m °C 0,024</b>
Tensile strength.....	<b>Kg/mm<sup>2</sup> 24</b>
Yield strength.....	<b>Kg/mm<sup>2</sup> 20</b>
Modulus of elasticity .....	<b>Kg/mm<sup>2</sup> 6.700</b>
Brinell hardness .....	<b>HB 70÷80</b>
Melting range.....	<b>°C 600-650</b>
O-ring material .....	<b>NBR 70</b>
Operating temperature.....	<b>°C -20/+120</b>
Screw material .....	<b>Steel class 8.8</b>
Screw driving torque .....	<b>Nm 10÷13,5 (90÷120 Inch Lbs)</b>
Outlet thread .....	<b>BSP or NPT</b>
Terminal thread .....	<b>BSP or NPT</b>
Max operating pressure .....	<b>15 bar - 1,5 MPa - 217 psi</b>
Failure test pressure .....	<b>56 bar - 5,6 MPa - 813 psi</b>

### Compatibility with fluids

Compressed air, Vacuum, Argon, Nitrogen, Carbon dioxide, Mineral oil\*, Synthetic oil\*, Other fluids\*.

### \*WARNING!

For further information, please apply to Teseo srl technical department.

## PROFILES SECTION OVER VIEW

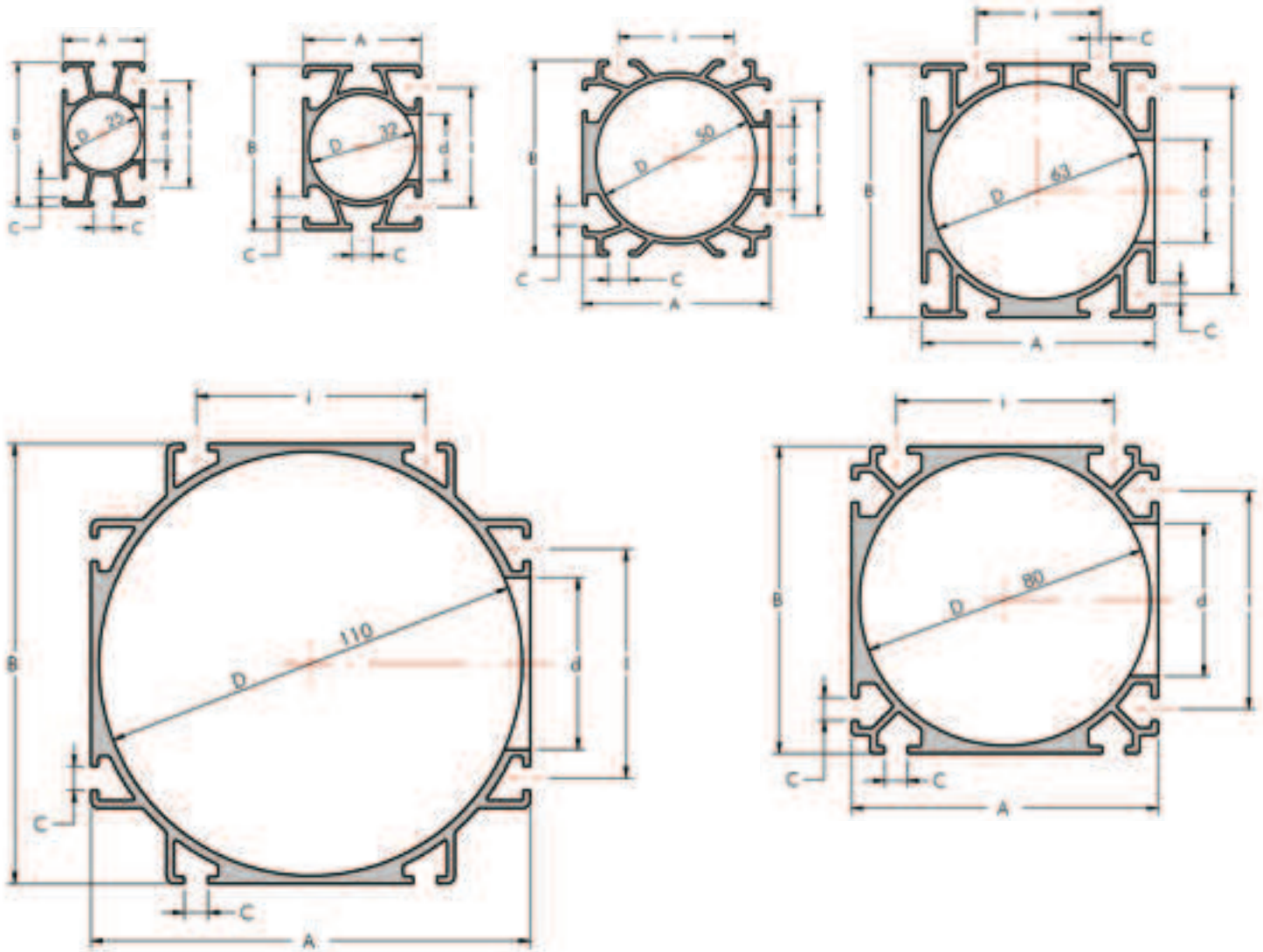

### SIZE DIMENSIONS

HBS	Dimensions						Max hole	Inner volume	Weight	Moment of inertia		Section Area
D mm	A mm	B mm	l mm	i mm	C mm	d mm	V l/m	P g/m	Jx cm <sup>4</sup>	Jy cm <sup>4</sup>	cm <sup>2</sup>	
25	28	49	36	-	6,2	18	0,5	730	6,80	3,00	5	
32	36	50	36	-	6,2	20	0,8	1300	12,30	6,70	8	
50	60	60	36	36	6,2	20	2,0	1900	26,40	35,00	20	
63	68	74	60	36	6,2	20/30	3,1	2940	78,60	63,30	31	
80	85	85	60	60	6,2	42	5,0	3300	120,20	120,20	50	
110	115	115	60	60	6,2	43	9,5	4200	261,50	261,50	95	

## NATURAL ALUMINIUM EXTRUDED PIPE



D mm	L m	Part. no.	P Kg.	n°	
25	5	800 028 500	4,0	32	
32	5	800 036 500	5,7	24	
50	5	800 060 500	9,0	16	
63	5	800 068 500	13,8	12	
80	5	800 085 500	16,7	8	
110	5	800 114 500	21,0	4	

D mm	L m	Part. no.	P Kg.	n°	
25	2,5	800 028 250	2,0	32	
32	2,5	800 036 250	2,9	24	
50	2,5	800 060 250	4,5	16	
63	2,5	800 068 250	6,9	12	
80	2,5	800 085 250	8,3	8	
110	2,5	800 114 250	10,5	4	

## ANODIZED ALUMINIUM EXTRUDED PIPE



D mm	L m	Part. no.	P Kg.	n°	
25	5	801 028 500	4,0	32	
32	5	801 036 500	6,3	24	
50	5	801 060 500	9,5	16	
63	5	801 068 500	14,0	12	
80	5	801 085 500	17,0	8	
110	5	801 114 500	21,3	4	

D mm	L m	Part. no.	P Kg.	n°	
25	2,5	801 028 250	2,0	32	
32	2,5	801 036 250	3,1	24	
50	2,5	801 060 250	4,7	16	
63	2,5	801 068 250	7,0	12	
80	2,5	801 085 250	8,5	8	
110	2,5	801 114 250	10,6	4	

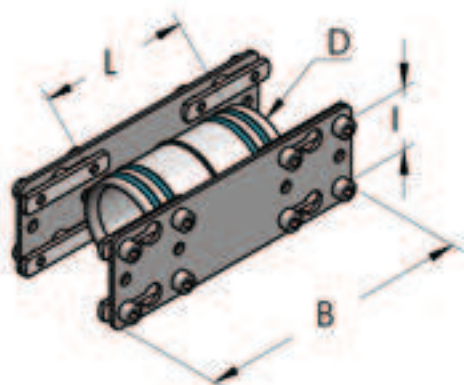
**STRAIGHT JOINT, COMPLETE**

D mm	I mm	L mm	B mm	Part. no.	P g	n°
25	36	50	120	003 000 020	180	20
32	36	65	120	003 001 020	200	20
50	36	90	160	003 002 020	570	10
63	36-60	106	160	003 003 020	770	10
80	60	130	160	003 004 020	950	10
110	60	180	230	003 005 020	2000	5

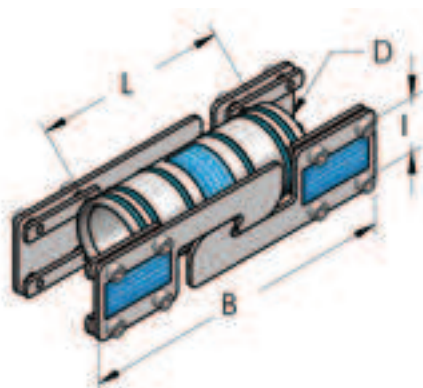
**SLIDING JOINT, COMPLETE**

D mm	I mm	L mm	B mm	Part. no.	P g	n°
25	36	75	200	003 000 021	420	10
32	36	95	200	003 001 021	450	10
50	36	130	200	003 002 021	780	10
63	60	150	200	003 003 021	1000	5
80	60	180	200	003 004 021	1400	5
110	60	280	280	003 005 021	2500	5

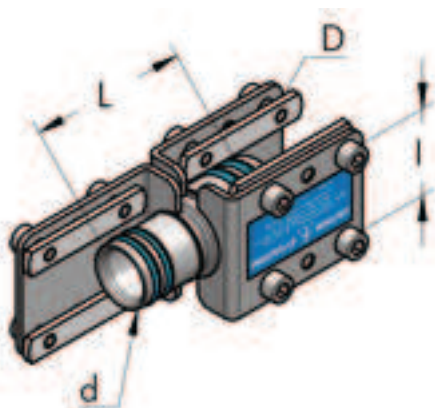
**REDUCTION JOINT STRAIGHT, COMPLETE**

D mm	d mm	L mm	I mm	Part. no.	P g	n°
32	25	66	36	003 001 049	270	10
50	32	88	36	003 002 049	621	10
63	50	105	36	003 003 049	777	5
80	63	125	60	003 004 049	1470	5
110	80	280	60	003 005 049	3000	2

## L JOINT, COMPLETE

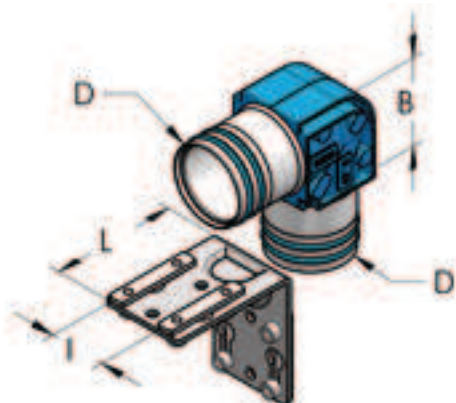

D mm	I mm	L mm	B mm	Part. no.	P g	n°
25	36	60	30	003 000 022	240	20
32	36	60	42	003 001 022	280	20
50	36	80	60	003 002 022	530	10
63	36-60	80	75	003 003 022	1400	10
80	60	80	85	003 004 022	2600	10
110	60	110	165	003 005 022	3000	5

## T JOINT, COMPLETE

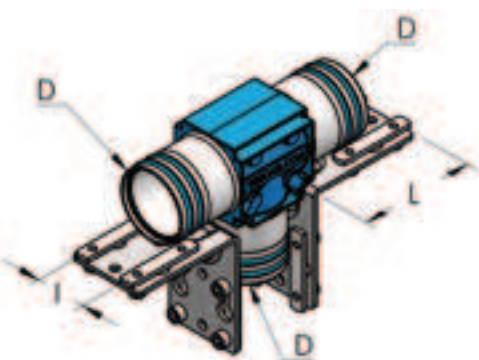

D mm	I mm	L mm	B mm	Part. no.	P g	n°
25	36	60	30	003 000 024	400	10
32	36	60	50	003 001 024	430	10
50	36	80	60	003 002 024	820	10
63	36-60	80	75	003 003 024	2100	10
80	60	80	85	003 004 024	3500	5
110/80	60	110	230	003 005 023	3900	2
110	60	110	230	003 005 024	4000	2

## CLOSED TERMINAL, COMPLETE

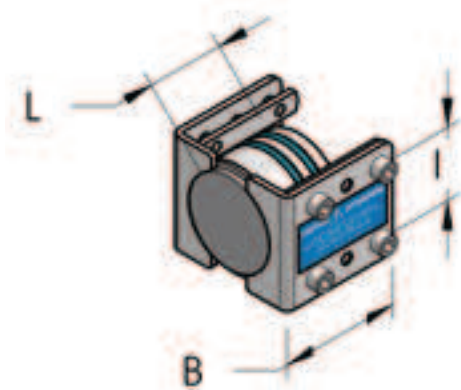

D mm	I mm	L mm	B mm	Part. no.	P g	n°
25	36	29	60	003 000 026	120	20
32	36	32	60	003 001 026	120	20
50	36	40	60	003 002 026	430	10
63	60	40	60	003 003 026	700	10
80	60	66	80	003 004 026	1350	5
110	60	150	110	003 005 026	2000	2

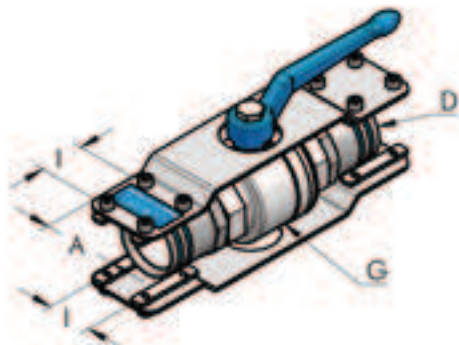
**BALL VALVE, COMPLETE**

D mm	G	I mm	A mm	Part. no.	P g	n°
25	3/4" - BSP	36	50	003 000 046	630	10
32	1" - BSP	36	50	003 001 046	1120	10
50	1 1/2" - BSP	36	60	003 002 046	2050	10
63	2" - BSP	36	60	003 003 046	3360	10
80	2 1/2" - BSP	60	72	003 004 046	5300	5
110	4" - BSP	60	78	003 005 046	12600	2

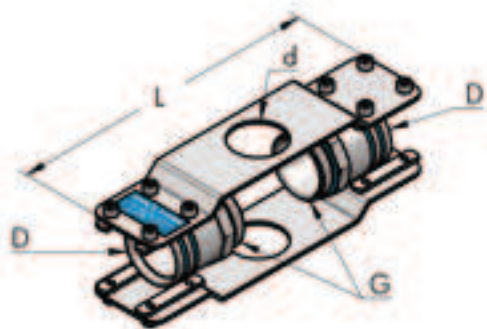
**KIT FOR BALL VALVE**

D mm	G	L mm	d mm	Part. no.	P g	n°
25	3/4" - BSP	220	30	003 000 047	340	10
32	1" - BSP	220	30	003 001 047	650	10
50	1 1/2" - BSP	250	42	003 002 047	740	10
63	2" - BSP	250	42	003 003 047	910	10
80	2 1/2" - BSP	-	-	003 004 047	1400	5

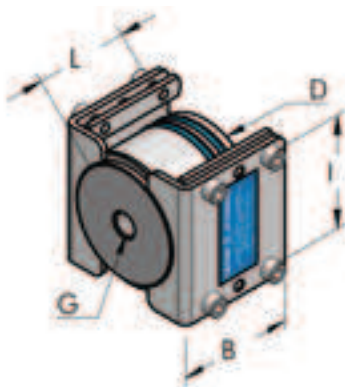
**TERMINAL WITH THREADED HOLE, COMPLETE**

D mm	G	L mm	B mm	I mm	Part. no.	P g	n°
25	1/4" - BSP	28	60	36	003 000 025	114	20
32	1/4" - BSP	32	60	36	003 001 025	130	20
32	1/2" - BSP	32	60	36	003 001 031	128	20
50	1/4" - BSP	40	60	36	003 002 025	440	20
50	1/2" - BSP	50	60	36	003 002 029	430	20
63	1/4" - BSP	50	60	60	003 003 025	656	20
80	1/4" - BSP	66	80	60	003 004 025	1300	20
80	1/2" - BSP	66	80	60	003 004 029	1300	20
110	3/8" - BSP	150	110	60	003 005 025	2000	2

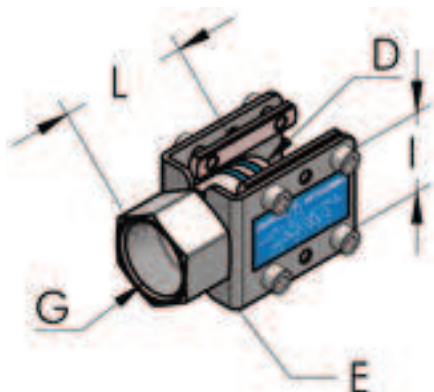

**TERMINAL THREADED FEMALE, COMPLETE**

D mm	G	E mm	L mm	I mm	Part. no.	P g	n°
25	3/4" - BSP	30	45	36	003 000 027	120	20
32	1" - BSP	36	60	36	003 001 027	140	20
50	1 1/2" - BSP	52	70	36	003 002 028	340	20
63	1 1/2" - BSP	65	72	60	003 003 028	440	10
80	1" - BSP	-	66	60	003 004 027	1300	20
80	2" - BSP	82	95	60	003 004 028	920	10
110	2 1/2" - BSP	115	150	60	003 005 028	2000	2

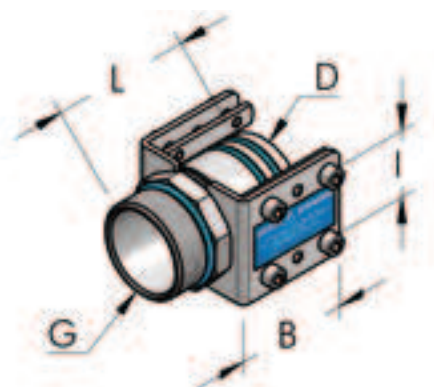
**NIPPLE THREADED MALE, COMPLETE**



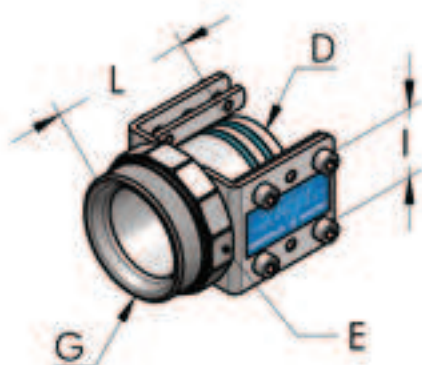



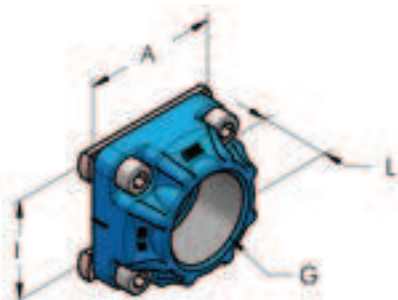

D mm	G	L mm	B mm	I mm	Part. no.	P g	n°
25	3/4" - BSP	47	60	36	003 000 029	110	20
32	1" - BSP	55	60	36	003 001 030	230	20
50	1 1/2" - BSP	76	60	36	003 002 030	330	20
63	2" - BSP	80	60	60	003 003 030	430	10
80	2 1/2" - BSP	100	80	60	003 004 030	650	10

**TERMINAL THREADED MALE, COMPLETE**

D mm	G	L mm	E mm	I mm	Part. no.	P g	n°
25	1" - BSP	45	36	36	003 000 030	130	20
32	1 1/4" - BSP	61	50	36	003 001 029	190	20
50	2" - BSP	75	65	36	003 002 031	440	20
63	2 1/2" - BSP	90	82	60	003 003 031	600	10
80	3" - BSP	110	90	60	003 004 031	830	10
110	4" - BSP	152	115	60	003 005 031	1500	5







## FEMALE OUTLET PLATE, COMPLETE

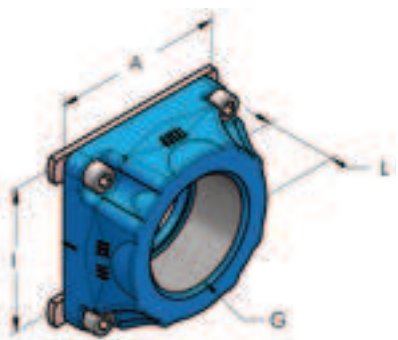

I mm	G	A mm	L mm	Part. no.	P g	n°	
36	1/8" - BSP	50	25	003 001 032	80	20	
36	1/4" - BSP	50	25	003 001 033	80	20	
36	3/8" - BSP	50	25	003 001 034	80	20	
36	1/2" - BSP	50	25	003 002 033	110	20	
36	3/4" - BSP	50	25	003 002 034	105	20	
36	1" - BSP	50	25	003 002 035	90	20	







## FEMALE OUTLET PLATE, COMPLETE

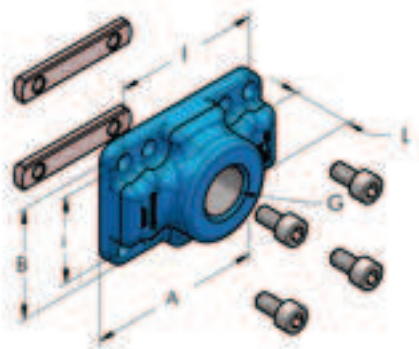

I mm	G	A mm	L mm	Part. no.	P g	n°	
60	1/2" - BSP	72	30	003 003 033	250	10	
60	3/4" - BSP	72	30	003 003 034	220	20	
60	1" - BSP	72	30	003 003 035	200	10	
60	1 1/2" - BSP	72	30	003 003 036	150	10	
60	1 1/4" - BSP	72	30	003 003 038	175	10	

## MODULAR OUTLET PLATE



I mm	i mm	G	A mm	B mm	L mm	Part. no.	P g	n°	
60	36	1/8" - BSP	72	48	25	003 360 030	140	10	
60	36	1/4" - BSP	72	48	25	003 360 031	137	10	
60	36	3/8" - BSP	72	48	25	003 360 032	133	10	
60	36	1/2" - BSP	72	48	25	003 360 033	129	10	
60	36	3/4" - BSP	72	48	25	003 360 034	125	10	
60	36	1" - BSP	72	48	25	003 360 035	120	10	

## MALE OUTLET PLATE, COMPLETE

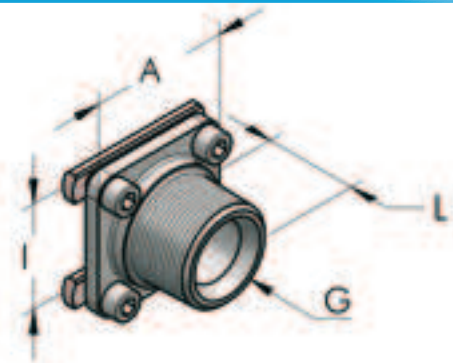

I mm	G	A mm	L mm	Part. no.	P g	n°	
36	1" - BSP	48	32	003 002 036	120	20	
60	2" - BSP	70	49	003 004 036	600	10	

## FEMALE MULTIPLE OUTLET PLATE, COMPLETE

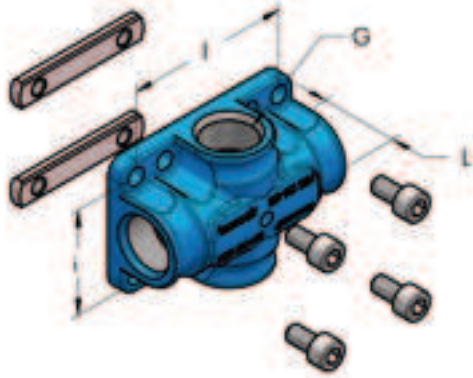

I mm	i mm	Holes	G	L mm	Part. no.	P g	n°	
36	36	2	1/4" - BSP	24	003 001 036	120	20	
36	36	2	3/8" - BSP	24	003 001 037	115	20	
36	36	4	1/4" - BSP	24	003 001 038	110	20	
36	36	4	3/8" - BSP	24	003 001 039	100	20	
60	36	4	1/4" - BSP	30	003 360 054	190	10	
60	36	4	3/8" - BSP	30	003 360 056	175	10	
60	36	4	1/2" - BSP	30	003 360 058	150	10	
60	36	2	1/2" - BSP	30	003 360 059	160	10	

## REDUCTION PLATE, COMPLETE

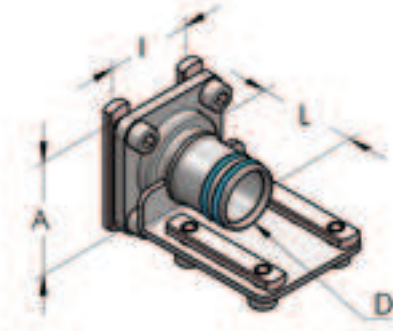

D mm	I mm	A mm	L mm	Part. no.	P g	n°	
25	36	48	40	003 000 037	190	20	
32	36	48	44	003 002 037	200	20	
50	60	70	60	003 003 037	530	10	
63	60	70	72	003 004 037	610	10	

## CONDENSATE LEVEL SPY HOLE

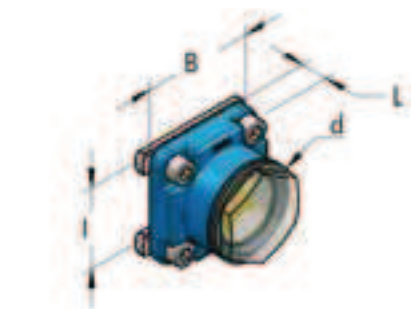

I mm	d mm	L mm	B mm	Part. no.	P g	n°	
36	40	10	48	003 001 044	100	20	
60	40	12	72	003 003 044	180	10	

## MANOMETER, COMPLETE

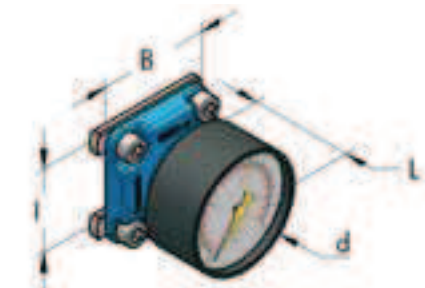

I mm	d mm	L mm	B mm	Part. no.	P g	n°	
36	50	45	48	003 001 048	144	10	
60	50	55	72	003 003 048	205	10	

**FLEXIBLE PIPE FOR CONNECTION TO COMPRESSOR**

D mm	G	L mm	d mm	Part. no.	P g	 n°
25	1" - BSP	1000	37	003 000 058	1700	20
32	1"1/4 - BSP	1000	44	003 001 058	2200	20
50	2" - BSP	1000	65	003 002 058	4000	20
63	2"1/2 - BSP	1300	77	003 003 058	4700	20
80	3" - BSP	1600	90	003 004 058	5800	20

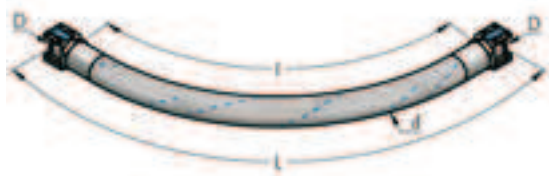
**FLEXIBLE JOINT FOR HBS-HBS CONNECTION**

D mm	d mm	L mm	I mm	Part. no.	P g	 n°
25	37	1000	1050	003 000 059	1900	10
32	44	1000	1080	003 001 059	2400	10
50	65	1000	1100	003 002 059	4300	10
63	77	1300	1450	003 003 059	5000	10
80	90	1600	1800	003 004 059	6300	10

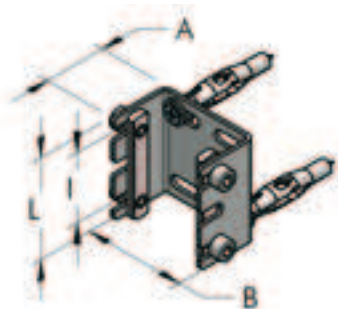
**U BRACKET, COMPLETE**

I mm	B mm	L mm	A mm	Part. no.	P g	 n°
36	50	52	30	003 000 040	140	20

For HBS 25 Only

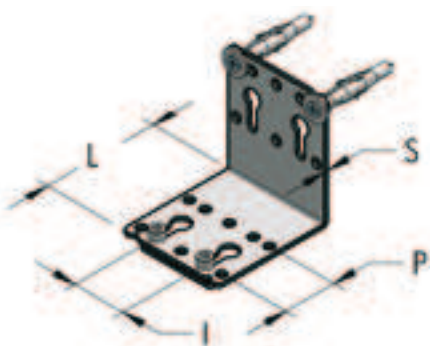
**L PLATE, COMPLETE**

I mm	P mm	L mm	S mm	Part. no.	P g	 n°
36	36	60	2	003 001 040	100	20
36-60	36	80	3	003 003 040	260	20
36-60	36-60	140	3,5	003 004 040	430	20

## SUPPORT BRACKET, COMPLETE

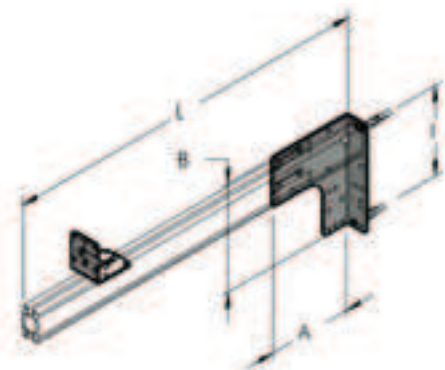

A mm	B mm	I mm	L mm	Part. no.	P g	n°	
130	170	140	600	003 001 070	1300	10	
130	170	140	*	003 001 071	360	10	

\*without bar

## ADHESIVE COLOUR STICKERS



L mm	Colour mm	Part. no.	P g	n°	
310	Blue RAL 5015	104 025 150	29	11	
310	Brown RAL 8003	104 028 316	29	11	
310	Grey RAL 7000	104 028 317	29	11	
310	Red RAL 3020	104 028 318	29	11	
310	Yellow RAL 1028	104 028 319	29	11	
310	Green RAL 6029	104 028 315	29	11	

## DEMO SUIT-CASE

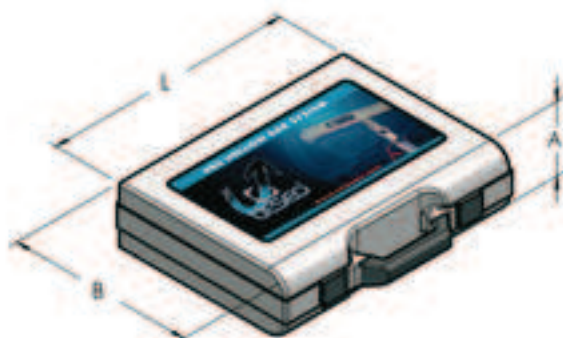

A mm	B mm	L mm	Configuration	Part. no.	P g	n°	
130	380	490	22 HBS parts	003 001 090	4500	1	

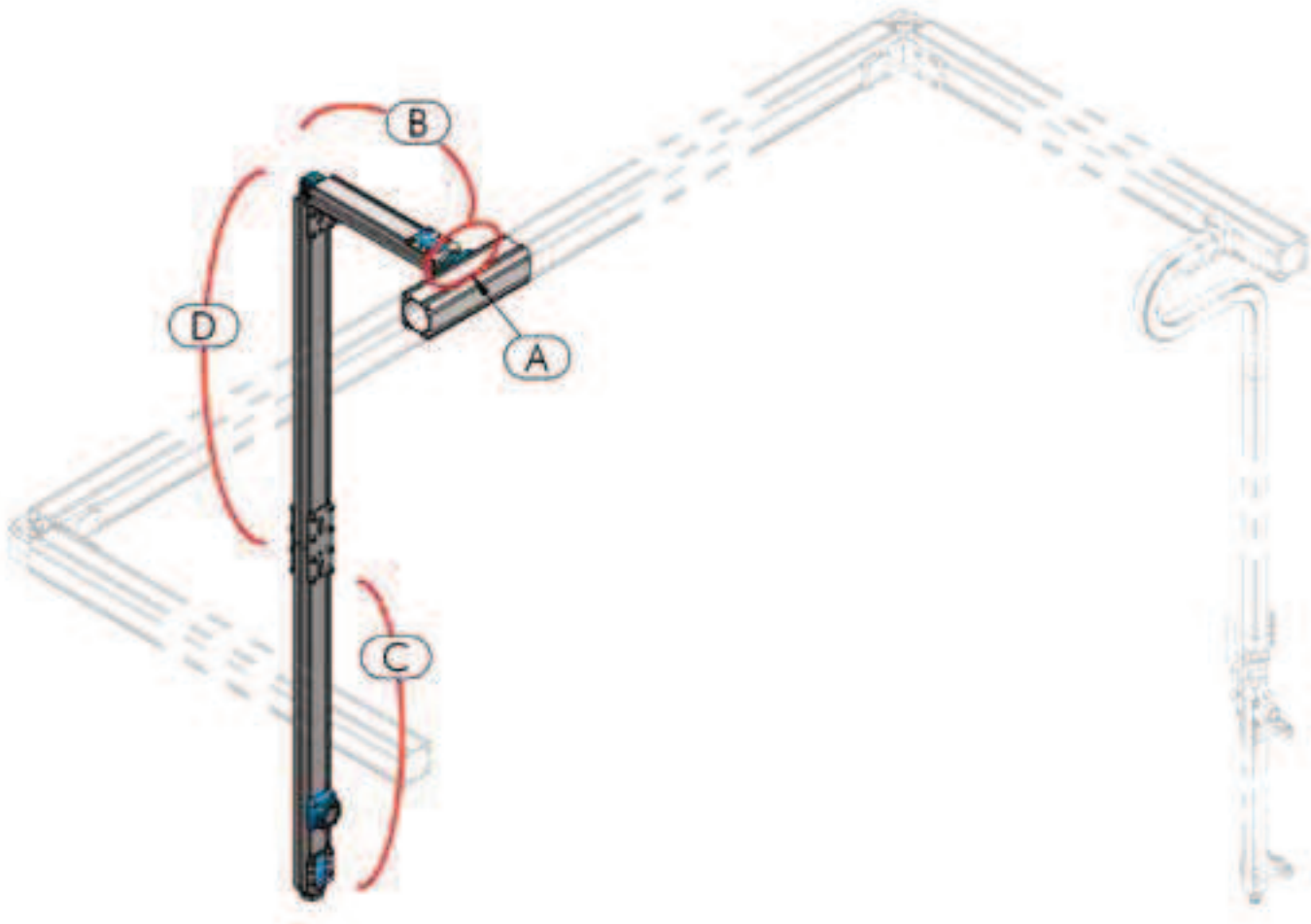

## CREATE YOUR DROP COLUMN

- A - Confirm the characteristics of your main line and of the secondary lines that derive from it, to define a components list.
- B - Study the route from the main line that the secondary lines have to take and choose the components and pipework needed.
- C - Define the types of end of line attachments required and choose the appropriate components.
- D - Verify the pipework's route from B to C and choose the quantity of pipework and the components needed

A	HBS pages 24-25-26-30 AP pag. 50
B	HBS pages 20-22-27 AP pages 42-43-46-51-52
C	HBS pages 20-21-22-23-24-25-26-27-30 AP pages 43-44-45-46-47-51
D	HBS pages 20-21-30 AP pages 42-43

## REDUCTION PLATE FOR D14 COLUMN, COMPLETE

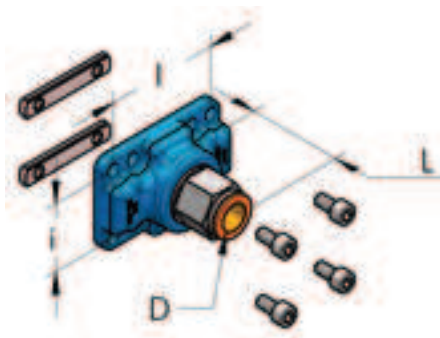

I mm	i mm	D mm	L mm	Part. no.	P g	n°	
36	36	14	50	003 001 134	160	20	
60	60	14	55	003 003 134	300	20	
60	36	14	55	003 360 134	170	20	

## 3 OUTLET BLOCK FOR COLUMN DROP D14, COMPLETE

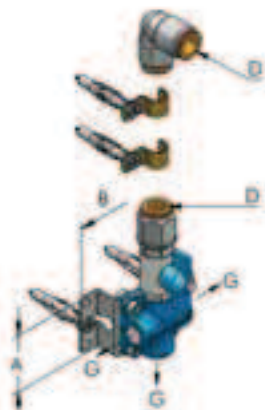

D mm	G	A mm	B mm	Part. no.	P g	n°	
14	3/8" - BSP	48	85	003 001 068	500	20	
14	1/2" - BSP	48	85	003 002 068	520	20	

## STRAIGHT PIPE FOR COLUMN DROP D14

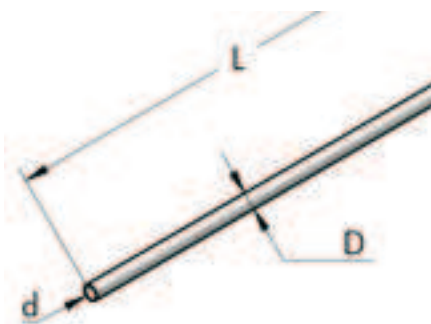

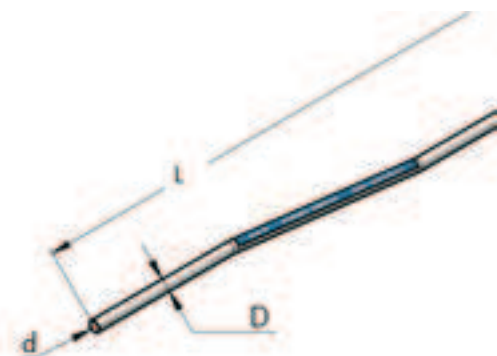

D mm	d mm	L m	Part. no.	P g	n°	
14	12	1	425 014 100	106	20	
14	12	5	425 014 500	530	20	

## BENT PIPE FOR COLUMN DROP D14

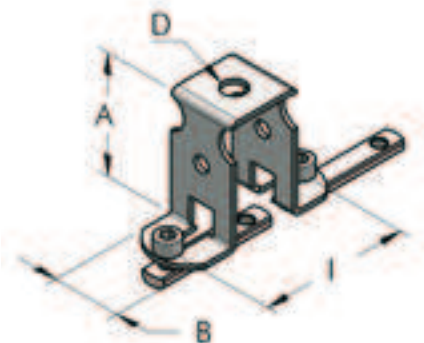

D mm	d mm	L m	Part. no.	P g	n°	
14	12	5	804 014 500	535	20	

**HANGING BRACKET, COMPLETE**

I mm	A mm	B mm	D mm	Part. no.	P g	 n°
36-60	50	28	10	003 001 074	100	20

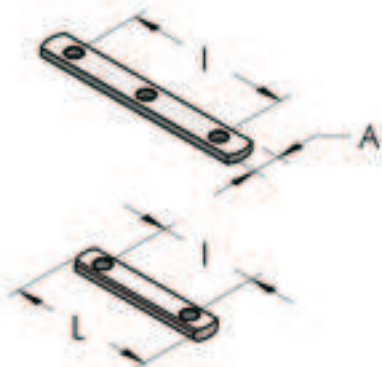
**SMALL PLATE WITH M6 HOLES**

I mm	A mm	L mm	holes	Part. no.	P g	 n°
36	10	56	2	725 010 056	12	100
60	10	80	2	725 010 080	23	50
60	10	78	3	725 010 081	22	50

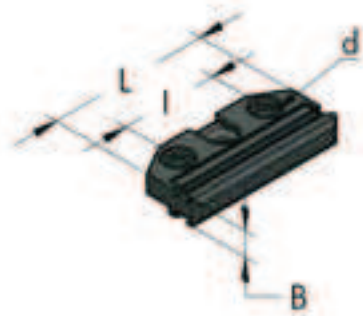
**INSULATING BLOCK**

d mm	L mm	I mm	B mm	Part. no.	P g	 n°
6	60	36	10	003 001 075	26	20

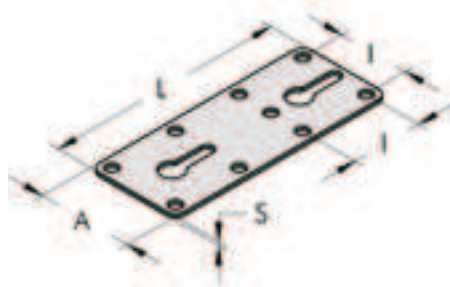
**STRAIGHT PLATE, IN GALVANIZED STEEL**

A mm	L mm	I mm	S mm	Part. no.	P g	 n°
48	120	36	2	711 048 120	80	20
54	160	36	2,5	711 056 160	146	20
72	160	36-60	2,5	711 072 160	201	20
78	240	36-60	3,5	711 078 230	422	20



## L PLATE, IN GALVANIZED STEEL

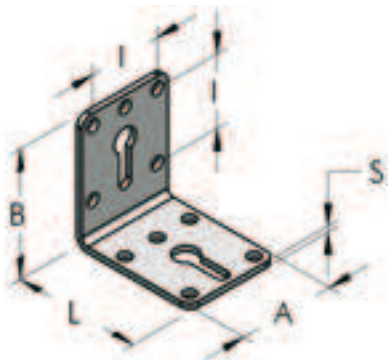

A mm	B mm	L mm	I mm	S mm	Part. no.	P g	n°
48	60	60	36	2	721 048 060	77	20
54	80	80	36	2,5	732 056 080	148	20
72	80	80	36-60	3	732 072 090	245	20
78	94	140	36-60	3,5	732 078 140	420	20

## FIXING BRACKET, IN GALVANIZED STEEL

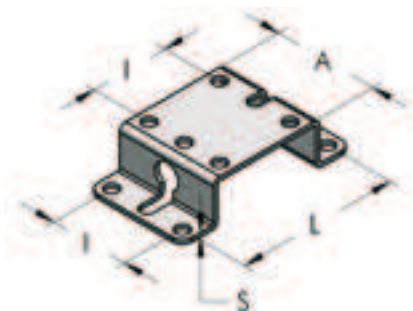

A mm	L mm	I mm	S mm	Part. no.	P g	n°
48	72	36	2	735 048 120	78	20

## O-RING SEAL IN NBR70



D mm	d mm	Cod. AS-BS	Part. no.	P g	n°
25	1,78	019	271 020 002	0,4	100
25	2	0210-02	271 021 002	0,5	100
29	3	0230-03	271 023 003	0,7	100
32	2,62	121	271 027 003	0,7	100
32	3	0260-03	271 026 003	0,8	100
50	2,62	132	271 044 003	1	100
50	3	0440-03	271 043 003	1,3	100
63	2,62	140	271 057 003	1,2	100
63	3	0560-03	271 056 003	1,5	100
80	2,62	150	271 073 003	1,5	100
110	3,53	241	271 101 004	4	100

## ALLEN SCREW, IN GALVANIZED STEEL

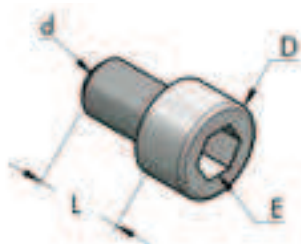

d mm	L mm	D mm	E mm	Part. no.	P g	n°
M6	8	10	5	212 006 008	4,2	100
M6	10	10	5	212 006 010	4,5	100
M6	12	10	5	212 006 012	4,8	100
M6	14	10	5	212 006 014	5,0	100
M6	18	10	5	212 006 018	5,8	100

## BASIC TOOLS BOX

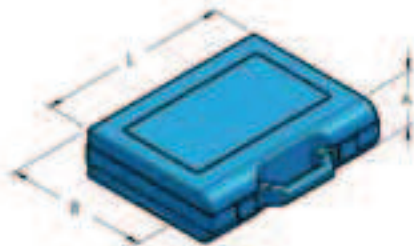

A mm	B mm	L mm	Part. no.	P g	 n°
50	190	240	003 001 092	700	1

## DRILLING JIG

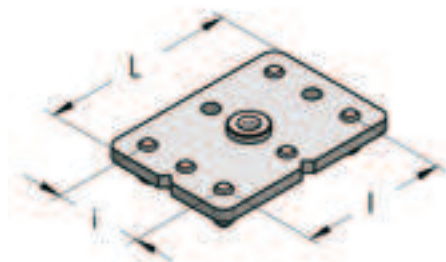

l mm	i mm	L mm	Part. no.	P g	 n°
60	36	80	911 036 060	190	1

## TUBES TO HOLD SMALL PLATE IN POSITION

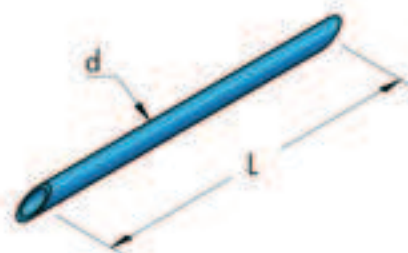

d mm	L mm	Mat	Part. no.	P g	 n°
8	150	PVC	421 006 015	5	10



## VASELINE GREASE

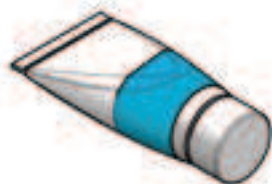

Part. no.	P g	 n°
111 003 100	850	20
111 003 010	100	20

## PTFE BLUE GREASE



Part. no.	P g	 n°
114 003 005	50	20 

## TERMINAL WITH THREADED HOLE, COMPLETE

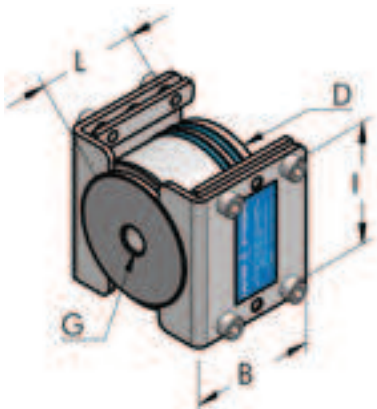

D mm	G	L mm	B mm	I mm	Part. no.	P g	n°	
25	1/4" - NPT	22	60	36	003 000 425	114	20	
32	1/4" - NPT	25	60	36	003 001 425	130	20	
32	1/2" - NPT	25	60	36	003 001 431	128	20	
50	1/4" - NPT	40	60	36	003 002 425	440	20	
50	1/2" - NPT	40	60	36	003 002 429	430	20	
63	1/4" - NPT	50	60	60	003 003 425	656	20	
80	1/4" - NPT	66	80	60	003 004 425	1300	20	
80	1/2" - NPT	66	80	60	003 004 429	1300	20	
110	3/8" - NPT	203	110	60	003 005 425	2000	20	

## TERMINAL THREADED FEMALE, COMPLETE

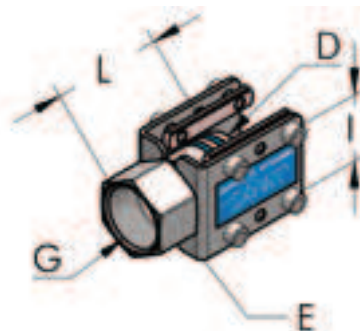

D mm	G	E mm	L mm	I mm	Part. no.	P g	n°	
25	3/4" - NPT	30	40	36	003 000 427	120	20	
32	1" - NPT	36	50	36	003 001 427	140	20	
50	1 1/2" - NPT	52	70	36	003 002 428	340	20	
63	1 1/2" - NPT	65	75	60	003 003 428	440	10	
80	1" - NPT	-	66	60	003 004 427	920	20	
80	2" - NPT	82	95	60	003 004 428	920	10	
110	2 1/2" - NPT	115	150	60	003 005 428	2000	20	

## NIPPLE THREADED MALE, COMPLETE

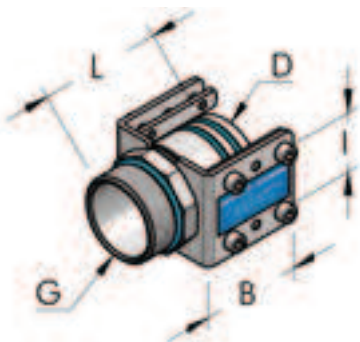

D mm	G	L mm	B mm	I mm	Part. no.	P g	n°	
25	3/4" - NPT	36	60	36	003 000 429	110	20	
32	1" - NPT	44	60	36	003 001 430	230	20	
50	1 1/2" - NPT	75	60	36	003 002 430	330	20	
63	2" - NPT	80	60	60	003 003 430	430	10	
80	2 1/2" - NPT	102	80	60	003 004 430	650	10	

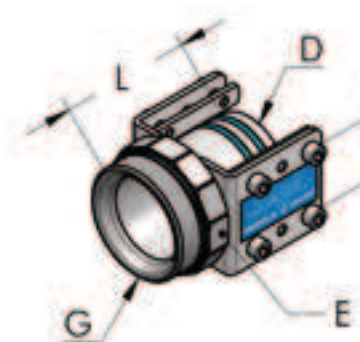

## TERMINAL THREADED MALE, COMPLETE



D mm	G	L mm	E mm	I mm	Part. no.	P g	n°	
25	1" - NPT	40	36	36	003 000 430	130	20	
32	1 1/4" - NPT	52	50	36	003 001 429	190	20	
50	2" - NPT	75	65	36	003 002 431	440	20	
63	2 1/2" - NPT	90	82	60	003 003 431	600	10	
80	3" - NPT	120	90	60	003 004 431	830	10	
110	4" - NPT	150	115	60	003 005 431	1500	20	

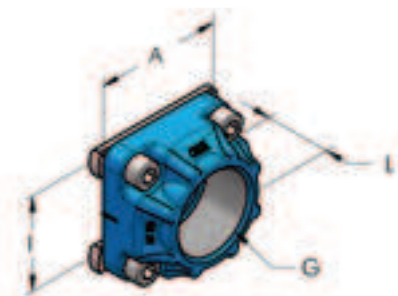



## FEMALE OUTLET PLATE, COMPLETE

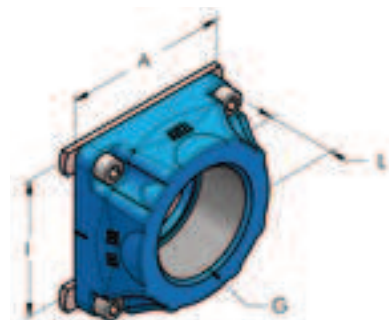

I mm	G	A mm	L mm	Part. no.	P g	n°	
36	1/8" - NPT	50	25	003 001 432	80	20	
36	1/4" - NPT	50	25	003 001 433	80	20	
36	3/8" - NPT	50	25	003 001 434	80	20	
36	1/2" - NPT	50	25	003 002 433	110	20	
36	3/4" - NPT	50	25	003 002 434	105	20	
36	1" - NPT	50	25	003 002 435	90	20	



## FEMALE OUTLET PLATE, COMPLETE



I mm	G	A mm	L mm	Part. no.	P g	n°	
60	1/2" - NPT	70	30	003 003 433	250	10	
60	3/4" - NPT	72	30	003 003 434	220	20	
60	1" - NPT	72	30	003 003 435	200	10	
60	1 1/2" - NPT	72	30	003 003 436	150	10	
60	1 1/4" - NPT	72	30	003 003 438	175	10	

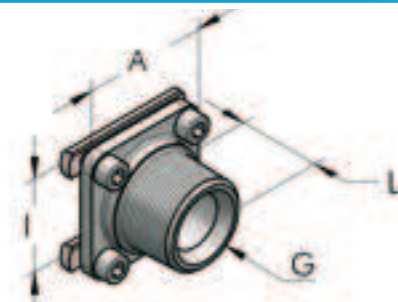



## MALE OUTLET PLATE, COMPLETE

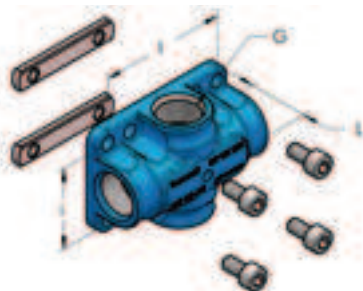

I mm	G	A mm	L mm	Part. no.	P g	n°	
36	1" - NPT	48	36	003 002 436	120	20	
60	2" - NPT	70	49	003 004 436	600	10	







## FEMALE MULTIPLE OUTLETS PLATE, COMPLETE



I mm	holes	G	L mm	Part. no.	P g	n°	
36	2	1/4" - NPT	24	003 001 436	120	20	
36	2	3/8" - NPT	24	003 001 437	115	20	
36	4	1/4" - NPT	24	003 001 438	110	20	
36	4	3/8" - NPT	24	003 001 439	100	20	

## FLEXIBLE PIPE FOR CONNECTION TO COMPRESSOR



D mm	G	L mm	d mm	Part. no.	P g	n°	
25	1" - NPT	1000	37	003 000 458	1700	20	
32	1 1/4" - NPT	1000	44	003 001 458	2200	20	
50	2" - NPT	1000	65	003 002 458	4000	20	
63	2 1/2" - NPT	1300	77	003 003 458	4700	20	
80	3" - NPT	1600	90	003 004 458	5800	20	

## COMPRESSED AIR AND FLUIDS PIPING SYSTEMS



## MODULAR MANIFOLDS INTEGRATED ON MACHINES

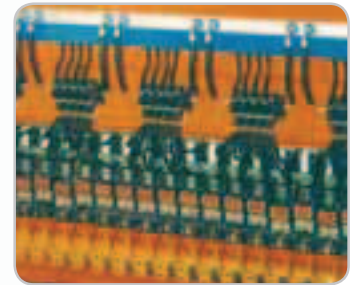

## ASSEMBLY AND PRODUCTION LINES



